

Fiberglass Wall Box Fan



 **Polymil Products, Inc.**

51 North Street/P.O. Box 125
LeRoy, NY 14482
Phone: (585) 768-8170
Fax: (585) 768-7830

Fiberglass Wall Box Fan Features

Features

- **Sizes:** 12" thru 60" direct drive.*
- **Model Designations:** BPF - Exhaust or Supply.
BPF-D - Exhaust or Supply with damper.
- **Construction:** Fiberglass, Hetron 99P ® polyester resin, Class 1 flame spread of 25 or less with UV inhibitor. Standard color is gray.
- **Wall Box:** Fiberglass construction with turned in flanges for rigidity. The wall box design facilitates the attachment of accessories such as dampers, guards, etc. and is shipped completely assembled. This "one-piece" design reduces installation costs. Synthetic veil provides smooth interior for air flow and creates a resin-rich, impenetrable surface to most airstream corrosives.
- **Venturi:** A fiberglass venturi orifice is molded into the wall box design increasing airflow efficiency.
- **Fan Propeller:** Highly efficient, air foil shaped fiberglass reinforced blades attached to a fiberglass hub. Bushing protected by a removable cap for easy maintenance.
- **Motor Mount:** Heavy duty fiberglass construction.
- **Motor:** NEMA Design B, severe duty, industrial continuous duty, totally enclosed with sealed ball bearings.
- **Hardware:** 304 stainless steel standard. Others available.
- **Face Flange:** 1-1/2" fiberglass flange.

* Other sizes are available. Consult factory.

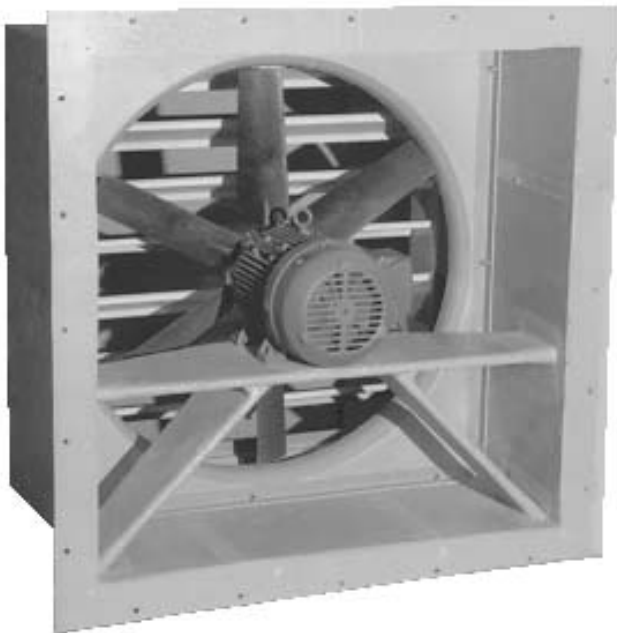

Accessories

- **Special Resins:** A variety of special resins are available to suit a specific corrosion application. Carbon impregnation is also available for explosive applications.
- **Hardware:** 316 stainless steel or monel.
- **Disconnect Switch:** Non-fused, mounted to the exterior of the unit in a NEMA 3R enclosure. Can be factory pre-wired to motor.
- **Front/Rear Guard:** 1/2" polyethylene mesh mounted in a PVC frame for easy removal.
- **Shutters:** Fiberglass construction, automatic or 115V motor actuated. Blades rotate in fiberglass reinforced polypropylene bearings.
- **Rain Hood:** For supply arrangements, fiberglass construction.

Fiberglass Wall Box Fan Dimensions

EXHAUST FAN

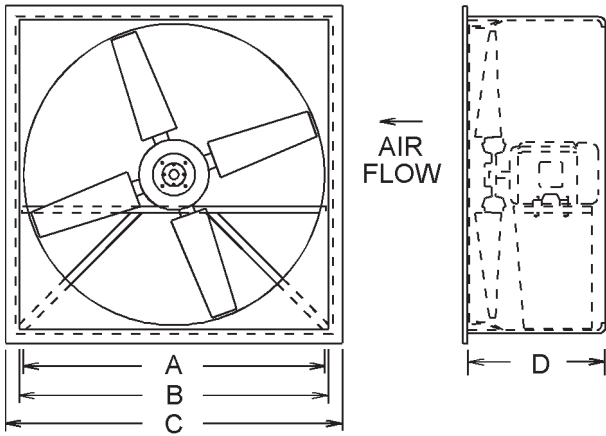

Exhaust Fan				
Prop Dia. A	B	C	D*	Housing Thickness
12	18	21	14	1/4
16	22	25	14	1/4
20	26	29	14	1/4
24	30	34	14	1/4
30	36	40	16	1/4
36	43	47	16	1/4
42	49	53	16	3/8
48	55	59	20	3/8
54	62	66	24	3/8
60	68	72	24	3/8

*Dimension may vary with horsepower

EXHAUST FAN WITH DAMPERS

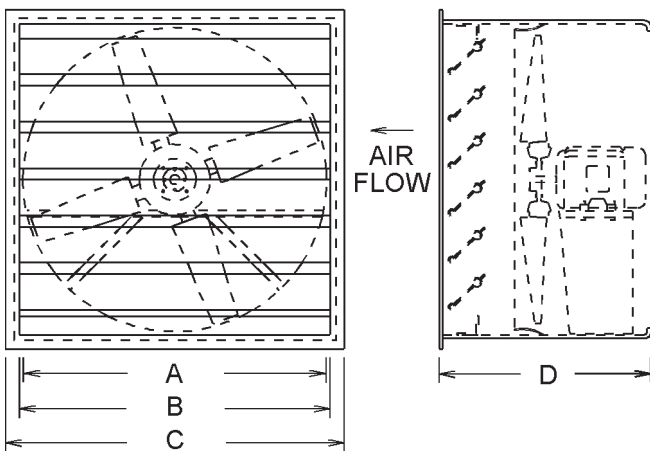

Exhaust Fan With Dampers				
Prop Dia. A	B	C	D*	Housing Thickness
12	18	21	27	1/4
16	22	25	27	1/4
20	26	29	27	1/4
24	30	34	27	1/4
30	36	40	29	1/4
36	43	47	30	1/4
42	49	53	32	3/8
48	55	59	33	3/8
54	62	66	35	3/8
60	68	72	36	3/8

*Dimension may vary with horsepower

Specifications

Furnish _____ each, size _____, Model (BPF, BPF-D) as manufactured by Polymil Products, Inc.

Unit shall be constructed of Hetron 99P® polyester resin with a Class 1 flamespread of 25 or less. Interior housing surface shall have a synthetic surfacing veil.

The fiberglass wall box housing shall have a minimum thickness of (1/4" for sizes 12" to 36" and 3/8" for sizes 42" to 60"). The fiberglass encapsulated motor mount shall be integrally molded to the wall box. The fiberglass venturi shall be arranged for either exhaust or supply operation.

Fan propeller is to be directly mounted to the motor shaft and rotate inside the venturi. Fiberglass blades shall have an air foil and helical design and attached to a fiberglass hub.

The fan shall have a capacity of _____ CFM at _____ inch(es) static pressure standard air and equipped with a _____ HP, _____ RPM, motor rated for severe duty service and suitable for _____ volt, _____ phase, _____ cycle operation.

All hardware shall be (304SS, 316SS, monel).

Available accessories include: disconnect switch mounted and wired, carbon impregnation with static grounding, 1/2" polyethylene mesh guard mounted in a removable PVC frame, fiberglass damper (automatic backdraft or 115v motor actuated), and fiberglass rain hood for supply arrangements.



51 North Street/P.O. Box 125

LeRoy, NY 14482

Phone: (585) 768-8170 Fax: (585) 768-7830

Visit our website at: www.polymil.com

email us at: sales@polymil.com