

Fiberglass Radial Centrifugal

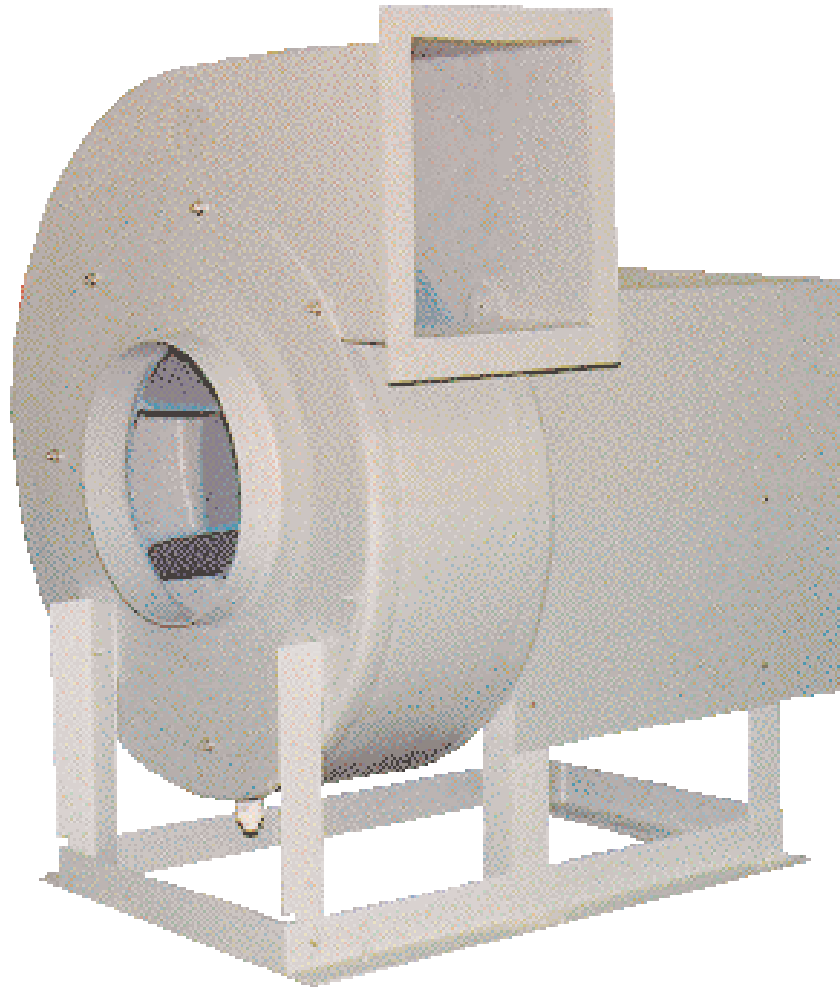

 **Polymil Products, Inc.**

51 North Street / P.O. Box 125
LeRoy, N.Y. 14482
Phone (585) 768-8170
Fax (585) 768-7830

Radial Centrifugal Features

Features

- **Sizes: Model RBC:** 8" thru 38".
- **Housing:** Fiberglass, Hetron 99P ® polyester resin, Class 1 flame spread of 25. Standard color is gray.
- **Wheel:** Radial blade design. Fiberglass, Hetron FR992 ® vinyl ester resin, Class 1 flame spread of 25. Metal hub insert is completely encapsulated in fiberglass. Fiberglass cap protects taperlock bushing. Final resin rich coat is applied for increased corrosion resistance.
- **Base:** Sizes 8" thru 17" have a solid fiberglass base and motor supports. Sizes 19" thru 38" have a heavy gauge all-welded steel base which is treated, primed and epoxy coated.
- **Shaft:** Steel, turned, ground and polished. Shaft is completely encapsulated with a fiberglass sleeve where it penetrates the housing.
- **Shaft Seal**
- **Hardware:** 304 stainless steel.
- **Inlet:** Slip fit style.
- **Outlet:** Flanged.
- **Drain:** 1" threaded PVC drain mounted on the lowest point of the scroll.
- **Motor Cover:** Fiberglass construction, provided as standard on drive arrangement 10 fans. Protects shafts, bearings, drive and motor.
- **Drive:** Adjustable sheave on units with a 1 - 3 HP motor. Fixed sheave on units with a 5 HP and above motor. 1.5 SF V-belts.

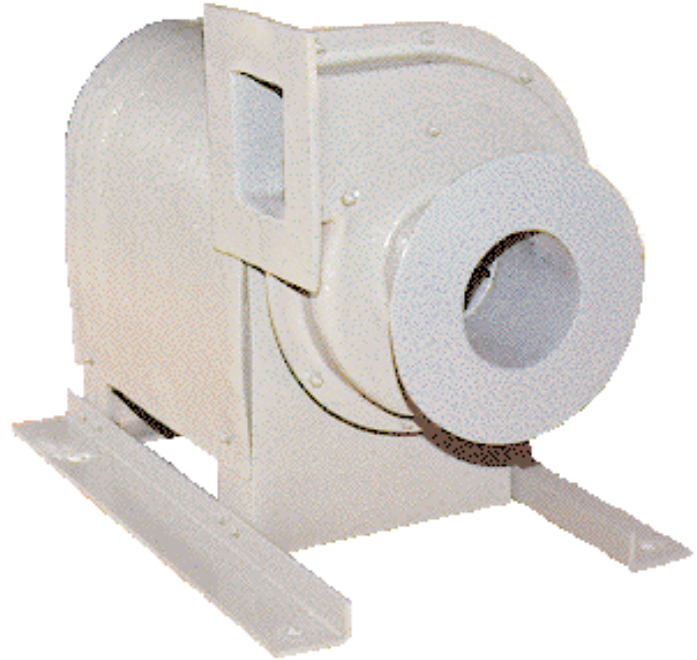

Accessories

- **Spark Resistant Construction:** Includes carbon veil, graphite impregnation and static grounding lugs to make unit electrically conductive, limiting the possibility of a static charge.
- **Special Resins:** A variety of special resins are available to suit a specific corrosive application.
- **Surface Veil:** Synthetic surface can be applied to all airstream surfaces to increase corrosion resistance of the fan.
- **Shaft:** Available in 304 or 316 stainless steel.
- **Hardware:** Available in 316 stainless steel.
- **Base:** Sizes 19" thru 38", sandblasted to a white metal, primed and epoxy coated.
- **Vibration Isolators:** Rubber-in-shear or spring type.
- **Access Door:** Allows access to interior of housing, Neoprene gasketed.
- **Flanged Inlet:** For flanged attachment to inlet duct.
- **Outlet Damper:** Fiberglass parallel blade, manual control damper with fiberglass hand quadrant to control air flow. Fiberglass automatic backdraft dampers also available.
- **Inlet Vane Dampers:** Fiberglass construction with manual quadrant for control of air flow.
- **Inlet Box:** Fiberglass construction, drilled and gasketed for field attachment to fan inlet.



Radial Centrifugal Dimensions

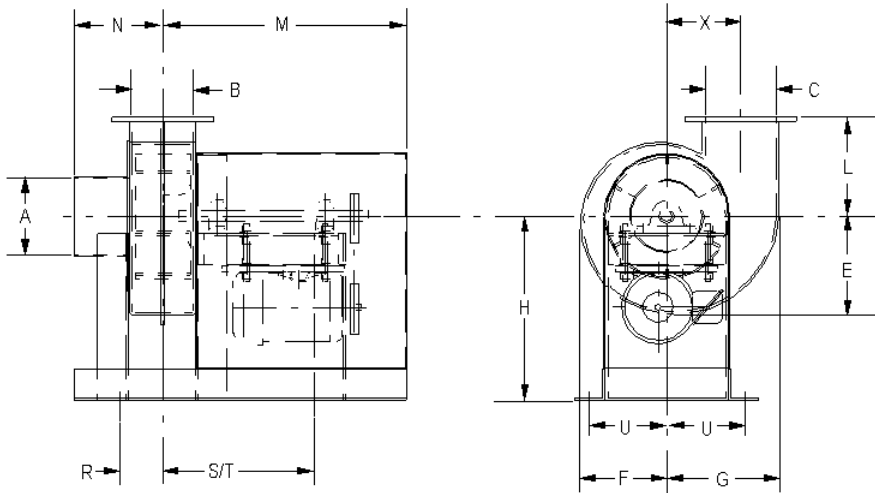

Sizes
8" - 19"

Outlet Detail

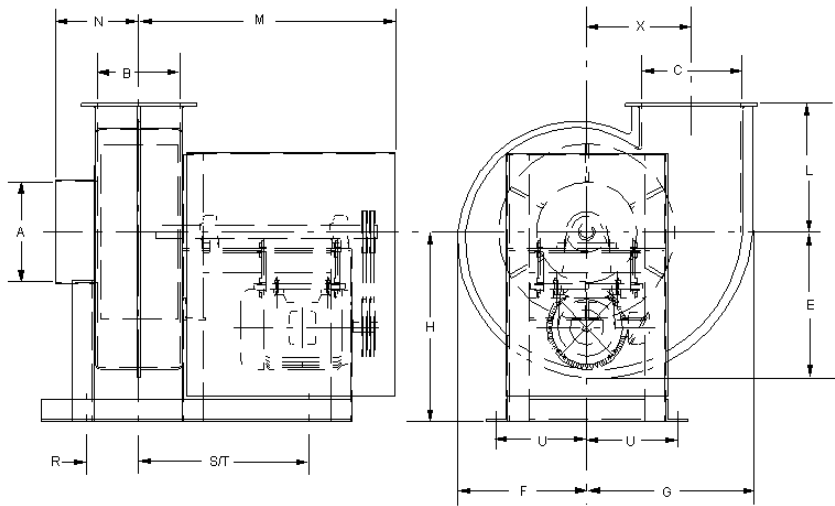
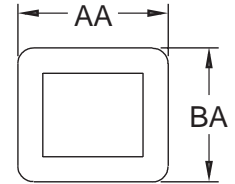

Sizes
21" - 38"

Size	8"	10"	12"	15"	17"	19"	21"	24"	28"	31"	33"	36"	38"
A	4-3/4	6	7-1/2	9	10	10-1/2	12	14	15-3/4	18	19-1/4	20	22
B	3-7/8	5	6	7	8-1/8	8-5/8	9-7/8	11-1/2	13-1/8	14-5/8	15-7/8	16-1/4	18
D	4-7/8	6	7	8-3/8	10	10-3/8	11-3/4	13-7/8	15-13/16	17-13/16	19-1/16	19-13/16	21-3/4
E	6-7/8	8-3/16	9-9/16	11-1/2	13-5/8	14-1/4	16-5/16	19-1/16	21-3/4	24-1/2	26-1/4	27-3/16	29-15/16
F	5-15/16	7-3/16	8-3/8	10-1/8	12	12-5/8	14-7/16	16-13/16	19-1/4	21-5/8	23-3/16	24-1/16	26-7/16
G	7-13/16	9-7/16	11	13-3/16	15-9/16	16-5/16	18-9/16	21-3/4	24-3/4	27-15/16	29-13/16	31	34-1/16
H	18	18	18	20	20	21	23	16-1/4	27	30-1/2	32	34	36-1/2
L	6-7/8	8-1/4	9-5/8	11-1/4	12-13/16	13-7/16	15-3/8	17-15/16	20-1/2	23	24-11/16	25-5/8	28-3/16
M	22-3/4	23-5/16	23-7/8	26-1/8	29	31-7/16	32-1/8	35-5/8	37-7/8	42-1/16	44-3/8	44-9/16	48
N	7-1/2	8-1/8	8-5/8	9-1/8	9-3/4	10	11-1/2	11-1/2	12-5/16	14-9/16	15-1/4	15-7/16	16-3/8
R	3	3-5/8	4-1/8	4-5/8	5-1/4	6-1/2	7-5/16	7-5/16	8-7/16	9-3/8	10-3/16	10-3/16	11
S/T	16-3/16	16-3/4	14-7/8	17-1/8	20	21-7/16	23-5/8	23-5/8	25-3/4	28-7/8	30-5/16	30-5/16	32-1/4
U	7-5/8	7-5/8	7-5/8	9-7/8	10-5/8	11-1/8	12-5/8	12-5/8	13-7/8	15-3/8	16-3/8	16-3/8	18-3/8
X	5-3/16	6-1/4	7-1/4	8-3/4	10-5/16	10-7/8	14-1/2	14-1/2	16-9/16	18-3/4	20	20-3/4	22-13/16
AA	8-7/8	10	11	12-7/8	14-1/2	14-7/8	18-3/8	18-3/8	20-13/16	22-13/16	24-1/16	24-13/16	26-3/4
BA	7-7/8	9	10	11-1/2	12-5/8	13-1/8	14-3/8	16	18-1/8	19-5/8	20-7/8	21-1/4	23

Specifications

Furnish _____ each, size _____, Model RBC as manufactured by Polymil Products, Inc.

Fan shall be suitable for Class II operation.

Housing shall be constructed of Hetron 99P® polyester resin with a Class 1 flamespread of 25 or less.

Fan wheel shall be constructed of fiberglass using Hetron 992 FR® vinyl ester resin and attached to shaft by a taperlock bushing. The bushing shall be protected by a fiberglass cover. Fan shaft shall be of carbon steel with a fiberglass sleeve where the shaft enters the fan housing and a shaft seal.

The fan shall have a capacity of _____ CFM at _____ inch(es) static pressure standard air and equipped with a _____ HP, _____ RPM, motor. It shall be NEMA design B, heavy duty, industrial continuous duty,

totally enclosed fan cooled and suitable for _____ volt, _____ phase, _____ cycle operation.

The bearings shall be self-aligning block type. Unit shall be equipped with a (fixed, adjustable) v-belt drive selected with a 1.5 service factor.

Motor and drive shall be protected by a fiberglass motor cover.

All hardware shall be (304SS, 316SS).

Available accessories include: carbon impregnation with static grounding, surface veil, vibration isolators (rubber-in-shear, spring type), neoprene gasketed access door, fiberglass flanged inlet, fiberglass manual control outlet damper, fiberglass inlet vane dampers with manual quadrant, fiberglass inlet box



51 North Street/P.O. Box 125

LeRoy, NY 14482

Phone: (585) 768-8170 Fax: (585) 768-7830

Visit our website at: www.polymil.com

Email us at: sales@polymil.com